

Time: 3 hour

Max. Marks: 80

Q1 is compulsory. Attempt any three from Q2 to Q6.

- Q1. Solve any Four 5 marks each**
- Explain working principle of Zener diode justify the same with characteristics and applications.
 - Explain the difference between BJT and FET.
 - Classify power amplifiers and compare them in brief.
 - Explain the concept of DC load line, Q point and region of operation of BJT with suitable diagram.
 - Define parameters of differential amplifier.

- Q2. 10 marks each**
- Determine the following for the network given below Fig. 1
Voltage gain, Current gain, input impedance and output impedance

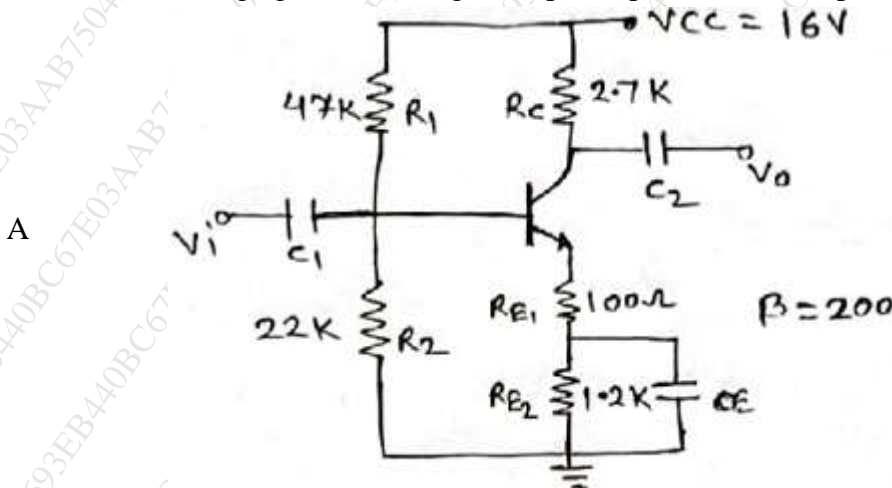

Fig. 1

- B** With neat diagram derive the efficiency of transformer coupled class –A power amplifier? State its uses.

- Q3**
- Explain construction and working of n-channel E-MOSFET **5 marks**
 - What is thermal runaway and how it can be avoided? **5 marks**
 - Calculate low cutoff frequencies due to coupling and bypass capacitors of the circuit given in fig. 2 **10 marks**

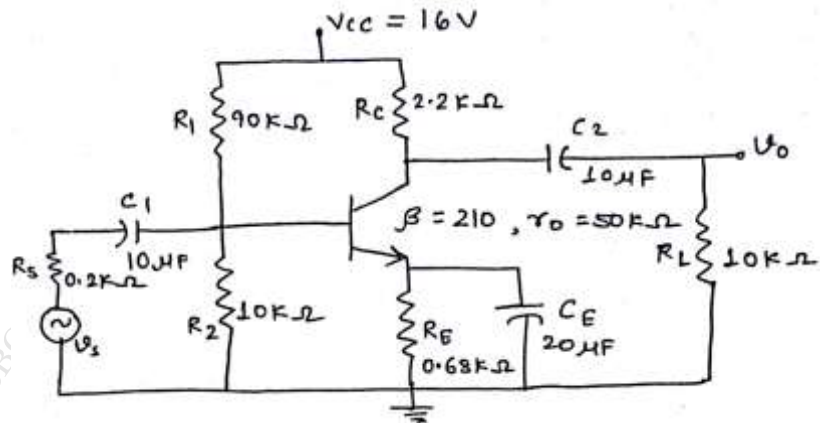

Fig. 2

Q4. (20 Marks)

A

Solve any Two

05 marks each

- i.
- ii.

State and explain Miller's Theorem.

Draw and explain operation of Depletion type MOSFET

- iii.

Differentiate Small Signal Amplifier and Large Signal Amplifier

B

Solve any One

10 marks each

- i.
- ii.

Draw circuit diagram of Class B Push Pull Power amplifier and explain its working. Find its maximum efficiency and maximum power dissipation in each transistor. What is crossover distortion? How can it be overcome?

Explain high frequency response of CS (E-MOSFET) amplifier.

Q5

A

Design a voltage divider bias circuit to operate at the given conditions.

Calculate the stability factors $S(I_{CO})$, $S(V_{BE})$, $S(\beta)$. Refer Fig. 3

10 Marks

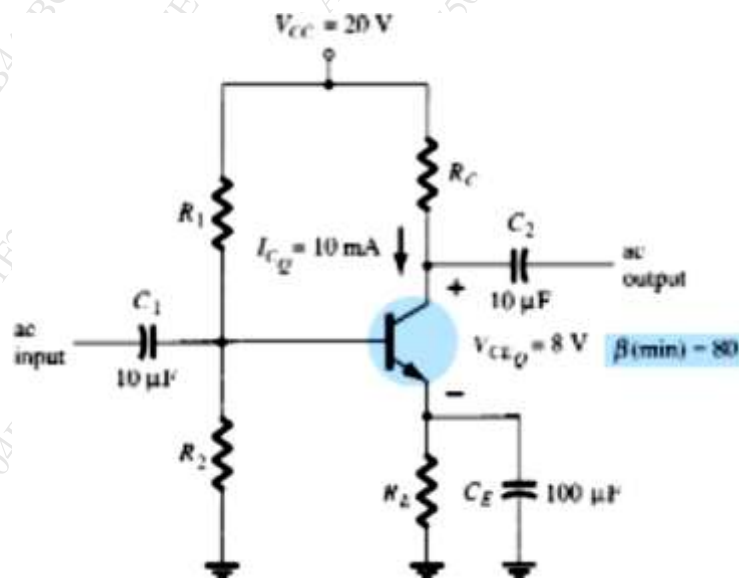

Fig. 3

- B Determine the input impedance, output impedance, voltage gain and current gain for the given circuit. Refer fig. 4 **10 Marks**

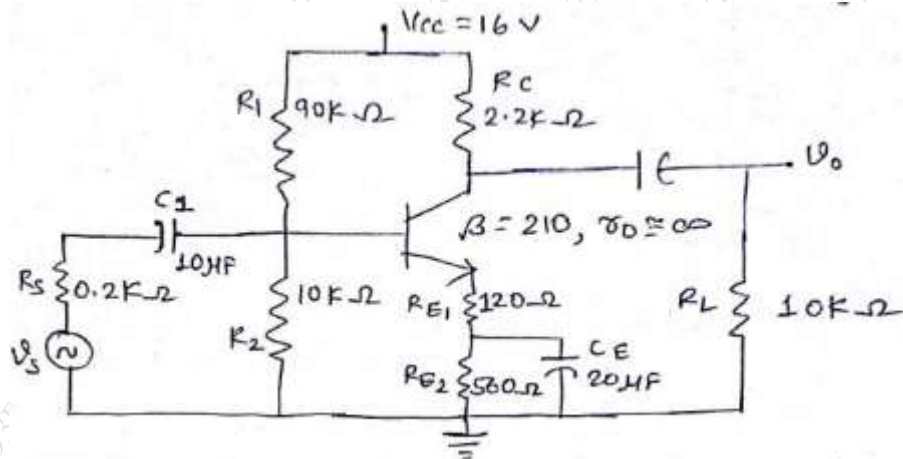

Fig. 4

Q6.

Write a short note on (Any Four) 05 marks each (20 Marks)

- Draw transfer characteristics and define JFET parameters from the same.
- High Frequency model of BJT CE configuration.
- Stability factor of various biasing techniques of BJT
- Why should be R_c as large as possible in design of CE amplifier?
- Transfer characteristics of P channel JFET
